

- **High Solids Concentration (25%)**
- **Completely Mixed—No Hot Spots**
- **Accepts quick lime up to 3/4" size**
- **Jacketed design for efficient heat utilization**
- **Forced draft wet scrubber for effective steam/dust removal**
- **Vibrating screen for grit removal (optional)**
- **7 different sizes (500 lbs—26,000 lbs)**
- **Available with fully automated controls package**

ZMI PORTEC DETENTION LIME SLAKER

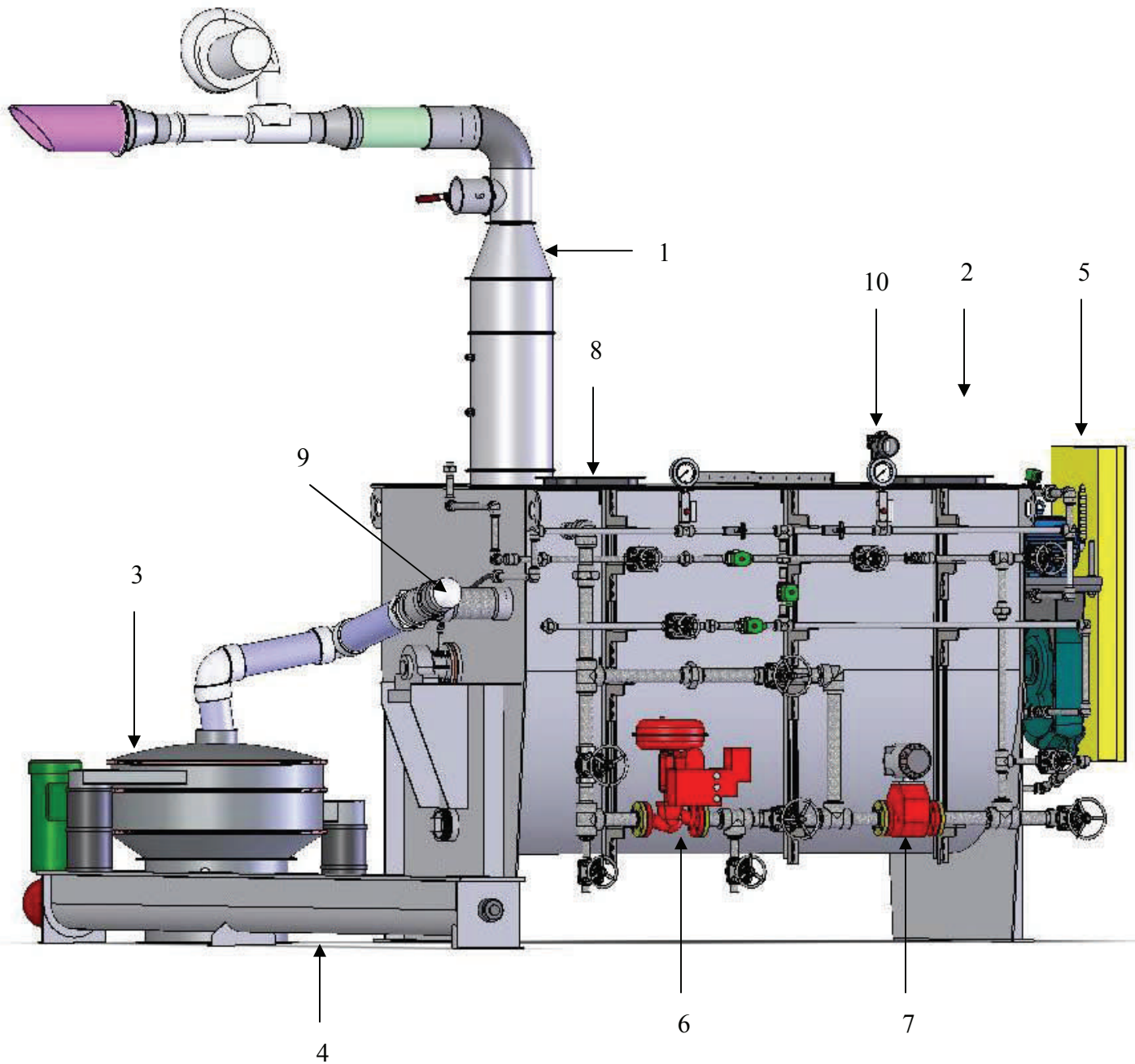

1. Wet Scrubber with Blower/Eductor

2. Lime Inlet Transition

3. Vibrating Screen

4. Grit Screw

5. Drive with Reducer

6. Slaking Water Flow Control Valve

7. Flow Meter

8. Inspection Doors

9. Slurry Discharge

10. Temperature Transmitter

SLAKER SPECIFICATIONS

SLAKING RATE (CAPACITY):

Seven different models available. Slaking rates ranging from 500 lb/hr to 26,000 lb/hr.

CONSTRUCTION:

ZMI slaker is all welded carbon steel construction (stainless steel available). The water jacket in the slaking zone provides for pre-heating of incoming slaking water, thus, in most cases, eliminating the need for pre-heaters. Jacket and barrel walls are rolled steel plates. Water piping is SCH40 standard but can be upgraded to meet customer requirements.

INSTRUMENTATION

Slaker is equipped with a temperature transmitter, a magnetic flow meter and a flow control valve to operate in a fully automated fashion after startup. The temperature transmitter controls the slaking water rate to operate the slaker at optimum slaking temperature.

Manual valves with solenoids control water to the seals and dust arrestor. Temperature operated valves supply emergency water in case of a temperature runoff.

Lime slaker also available with temperature switch, manual slaking water flow control valve and a flow indicator.

REPLACEABLE WEAR PLATES

Slaking chamber is fitted with wear plates made out of ¼" thick steel.

AGITATOR

Mixing in the slaking zone is provided by an agitator made from abrasion resistant steel. The agitator ensures complete mixing of water and lime. It also prevents formation of hot spots and keeps the grit in suspension at all times.

COMBINATION SEAL

A combination of a mechanical and a packed seal ensures that the slaker operates for a long time without any seal leak issues.

FORCED DRAFT VENTING

A dual spray wet scrubber combined with a forced draft venturi educator ensures that the slaker operates at slight vacuum in the slaking zone and all the dust and steam is effectively captured and removed safely. Clean air is vented to the outside while spray water with lime dust is returned to the slaker thus maintaining overall water balance.

GRIT SEPARATION

16-mesh, stainless steel vibrating screens act as a positive barrier to any grit and other larger particles and removes them from the slurry thus resulting in longer slurry pump impeller life. The diameter of the screen is based on the slurry flow through it.

GRIT SCREW

Grit removed by the screen is conveyed to disposal through a grit screw conveyor. The screw conveyor length and diameter is sized to meet the application requirements.

DRIVE PACKAGE

The agitator is driven by a combination of an appropriately sized motor, reducer and pulleys and V-belts. Motors are 3-phase, chemical duty and can be supplied to meet customer specifications.

ZMI PORTEC LIME SLAKERS

AVAILABLE IN SEVEN MODELS

500 to 26,000 lbs./hr

Model	CaO lbs./hr.	Drive HP
M-5	1,000	1.5
M-15	2,500	2.0
M-25	5,550	5.0
M-40	9,000	7.5
M-55	12,500	10.0
M-60	16,000	15.0
M-90	26,000	20.0

Detention Slaker



MUNICIPAL AND INDUSTRIAL APPLICATIONS

- *Water and Wastewater Treatment*
- *pH Control*
- *Water Softening*
- *Metal Precipitation*
- *Flue Gas Desulfurization*
- *Coal Storage Run-Off*
- *Heap Leach Mining*

Represented by:s



8485 Parkhill Drive
Milton, Ontario
CANADA
L9T 5E9